

**SPECIFICATION**  
**FOR**  
**LCM+CTP Module**

MODULE No:	KD038HDFPD002-C001A
CUSTOMER:	

STARTEK	INITIAL	DATE
PREPARED BY		
CHECKED BY		
APPROVED BY		

CUSTOMER	INITIAL	DATE
APPROVED BY		

### Revision History

Date	Rev. No.	Page	Summary
2021.04.13	V1.0	ALL	FIRST ISSUE

## Contents

1. Basic Specifications.....		4
1.1 TFT Features.....		4
1.2 CTP Features.....		4
1.3 Mechanical Information .....		5
2. Block Diagram .....		5
3. Outline dimension.....		6
4. Input terminal Pin Assignment.....		7
4.1 TFT Pin Assignment.....		7
4.2 CTP Pin Assignment.....		8
5. LCD Optical Characteristics.....		9
5.1 Optical specification.....		9
6. Electrical Characteristics .....		12
6.1 Absolute Maximum Rating.....		12
6.2 DC Electrical Characteristics .....		12
6.3 LED Backlight Characteristics .....		13
7. AC Characteristic.....		15
7.1 RGB Data format.....		15
7.2 General timing diagram .....		16
8. CTP Specification .....		18
8.1 Electrical Characteristics .....		18
8.1.1 Absolute Maximum Rating.....		18
8.1.2 DC Electrical Characteristics (Ta=25°C).....		18
8.1.3 AC Characteristics.....		19
8.2 I2C Timing .....		19
9. LCD Module Out-Going Quality Level.....		24
9.1 VISUAL & FUNCTION INSPECTION STANDARD .....		24
9.1.1 Inspection conditions .....		24
9.1.2 Definition .....		24
9.1.3 Sampling Plan .....		25
9.1.4 Criteria (Visual).....		26
11. Cautions and Handling Precautions.....		33
11.1 Handling and Operating the Module.....		33
11.2 Storage and Transportation.....		33
12. Packing.....		34

Part. No	KD038HDFPD002-C001A	REV	V1.0	Page 3 of 34
	常备库存 Stock For Sale	长期供货 Long Time supply	支持小量 NO MOQ	品种齐全 In Full Range

## 1. Basic Specifications

### \* Description

This is a color active matrix TFT (Thin Film Transistor) LCD (liquid crystal display) that uses amorphous silicon TFT as a switching device. This module is composed of a Transmissive type TFT-LCD Panel, driver circuit, capacitance touch panel, back-light unit. The resolution of a 3.8" TFT-LCD contains 1024X600 pixels, and can display up to 16.7M colors.

### 1.1 TFT Features

General Information Items	Specification	Unit	Note
	Main Panel		
Display area(AA)	82.6368(H)*48.42(V)	mm	
Driver element	TFT active matrix	-	
Display colors	16.7M	colors	
Number of pixels	1024(RGB)*600	dots	
Pixel arrangement	RGB vertical stripe	-	
Pixel pitch	0.0807(H)*0.0807(V)	mm	
Viewing angle	Free	o'clock	
Controller IC	JD9168	-	
LCM Interface	16/18/24/ BIT RGB	-	
Display mode	Transmissive /Normally black	-	
Operating temperature	-20~+70	°C	
Storage temperature	-30~+80	°C	
Module bonding technology	Use Optical bonding between LCM and CTP	-	-

### 1.2 CTP Features

General Information Items	Specification	Unit	Note
	Main Panel		
Resolution	1024(H)*600(V)	-	
Structure	G+G	-	
Controller IC	GT911	-	
Interface	I2C	-	
Slave Address	0x5D(7bit) or 0x14(7bit)	-	Note1
Touch mode	Five points	-	
Logic level	3.3	V	

**Note1:** For specific configuration method, please refer to section 8.2

Part. No	KD038HDFPD002-C001A	REV	V1.0	Page 4 of 34
常备库存 Stock For Sale	长期供货 Long Time supply	支持小量 NO MOQ	品种齐全 In Full Range	

### 1.3 Mechanical Information

Item		Min.	Typ.	Max.	Unit	Note
Module size	Horizontal(H)	-	97.92	-	mm	
	Vertical(V)	-	67.928	-	mm	
	Depth(D)	-	4.81	-	mm	
Weight		-	TBD	-	g	

### 2. Block Diagram

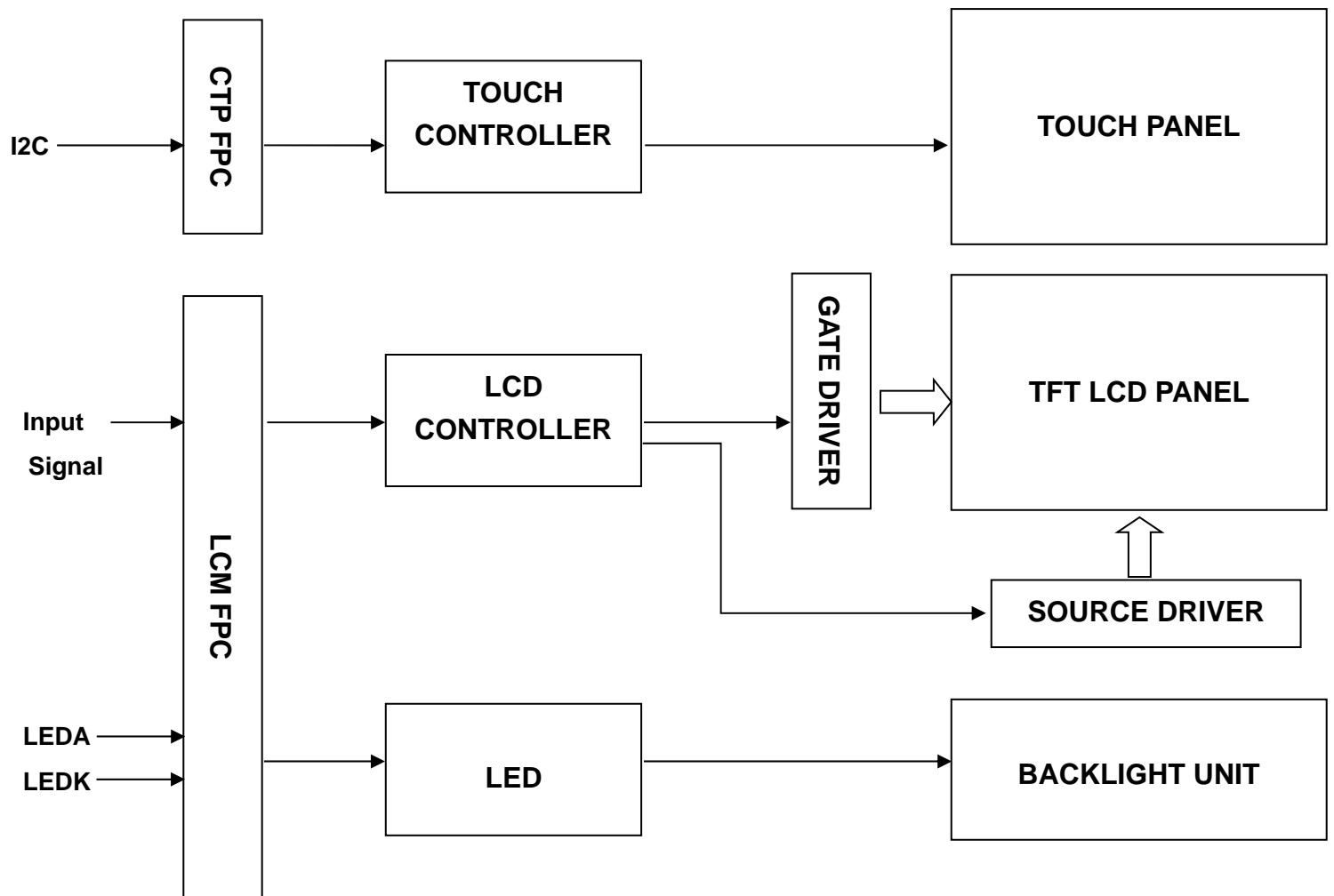

### 3. Outline dimension

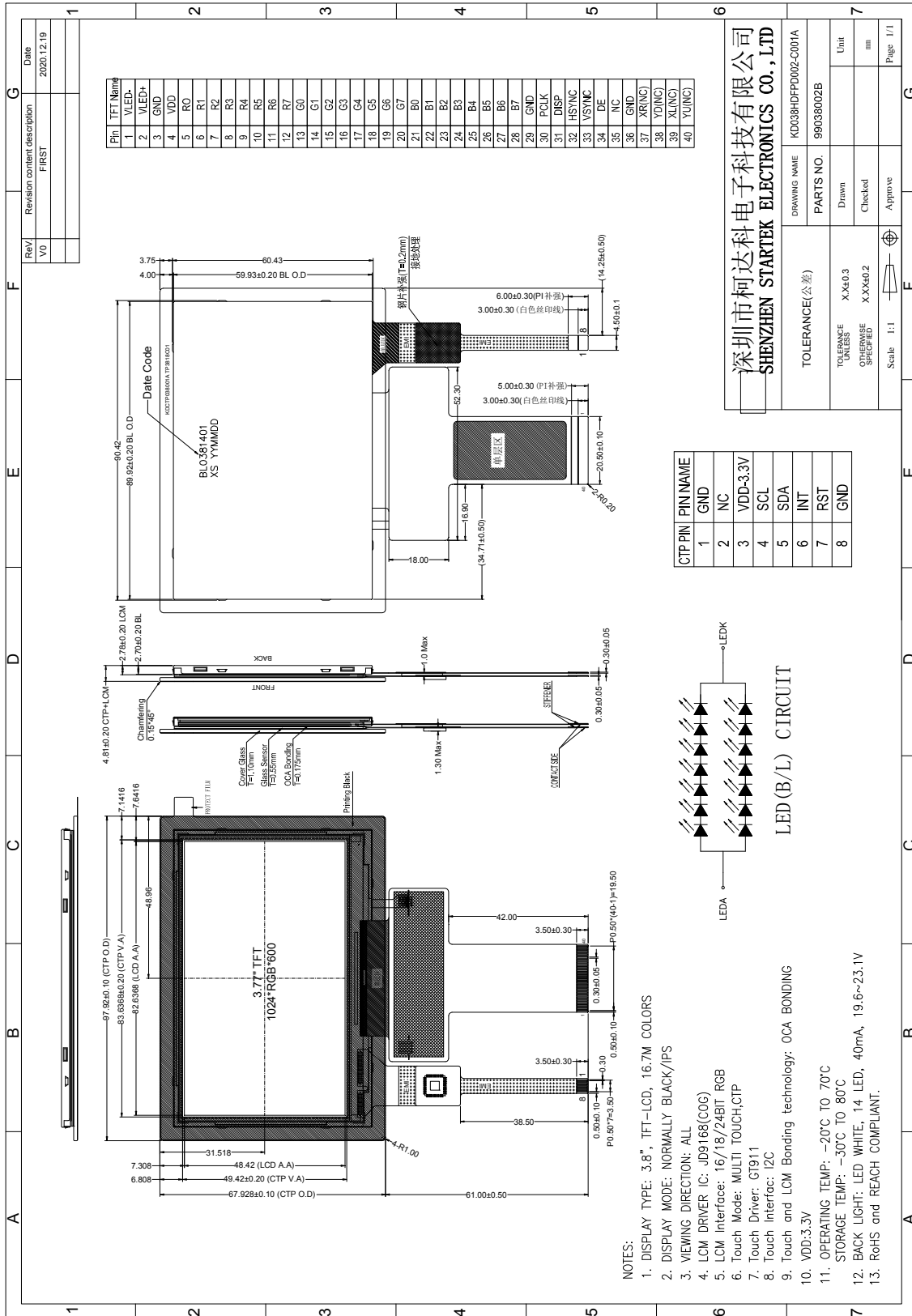

Part. No	KD038HDFPD002-C001A	REV	V1.0	Page 6 of 34
常备库存 Stock For Sale	长期供货 Long Time supply	支持小量 NO MOQ	品种齐全 In Full Range	

## 4. Input terminal Pin Assignment

### 4.1 TFT Pin Assignment

NO.	SYMBOL	DISCRIPTION	I/O
1	LEDK	Cathode pin of backlight.	P
2	LEDA	Anode pin of backlight.	P
3	GND	Ground.	P
4	VDD	Supply voltage(3.3V).	P
5-12	R0-R7	8-bit digital Red data input.	I/O
13-20	G0-G7	8-bit digital Green data input.	I/O
21-28	B0-B7	8-bit digital Blue data input.	I/O
29	GND	Ground.	P
30	PCLK	Clock signal; latching data at the falling edge.	I
31	DISP	Display control / standby mode selection. DISP = "Low" : Standby. DISP = "High" : Normal display.	I
32	HSYNC	Horizontal sync signal; negative polarity	I
33	VSYNC	Vertical sync signal; negative polarity	I
34	DE	Data input enable. Active High to enable the data input When not used in SYNC mode, user should connect it to "Low".	I
35	NC	--	--
36	GND	Ground.	P
37	XR(NC)	Touch panel Right Glass Terminal	A/D
38	YD(NC)	Touch panel Bottom Film Terminal	A/D
39	XL(NC)	Touch panel Left Glass Terminal	A/D
40	YU(NC)	Touch panel Top Film Terminal	A/D

Part. No	KD038HDFPD002-C001A	REV	V1.0	Page 7 of 34
常备库存 Stock For Sale	长期供货 Long Time supply	支持小量 NO MOQ	品种齐全 In Full Range	

#### 4.2 CTP Pin Assignment

NO.	SYMBOL	DISCRIPTION	I/O
1	GND	Ground.	P
2	NC	No Connection.	
3	VDD	Supply voltage.	P
4	SCL	I2C clock input.	I
5	SDA	I2C data input and output.	I
6	INT	External interrupt to the host.	I
7	RST	External Reset, Low is active.	I
8	GND	Ground.	P



## 5. LCD Optical Characteristics

### 5.1 Optical specification

Item	Symbol	Condition	Min.	Typ.	Max.	Unit.	Note	
Contrast Ratio	CR	$\Theta=0$ Normal viewing angle	800	1000	--		(1)(2)	
Response time	Rising		$T_{R+T_F}$	--	35	45	msec	(1)(3)
	Falling							
Uniformity	S(%)		37	42	--	%	C-light	
Color Filter Chromaticity	White		$W_X$	-0.04	0.3035	+0.04		
			$W_Y$		0.3400			
	Red		$R_X$		0.5797			
			$R_Y$		0.3360			
	Green		$G_X$		0.3570			
			$G_Y$		0.5381			
	Blue	$B_X$	0.1597					
		$B_Y$	0.1480					
Viewing angle	Hor.	$\Theta_L$	CR>10	75	85	--	(1)(4)	
		$\Theta_R$		75	85	--		
	Ver.	$\Theta_U$		75	85	--		
		$\Theta_D$		75	85	--		
Option View Direction	Free						(5)	

#### Measuring Condition

Measuring surrounding : dark room

Ambient temperature : 25±2℃

15min. warm-up time.

#### Measuring Equipment

FPM520 of Westar Display technologies, INC., which utilized SR-3 for Chromaticity and BM-5A for other optical characteristics.

Part. No	KD038HDFPD002-C001A	REV	V1.0	Page 9 of 34
常备库存 Stock For Sale	长期供货 Long Time supply	支持小量 NO MOQ	品种齐全 In Full Range	

**Note (1):** Definition of Viewing Angle :

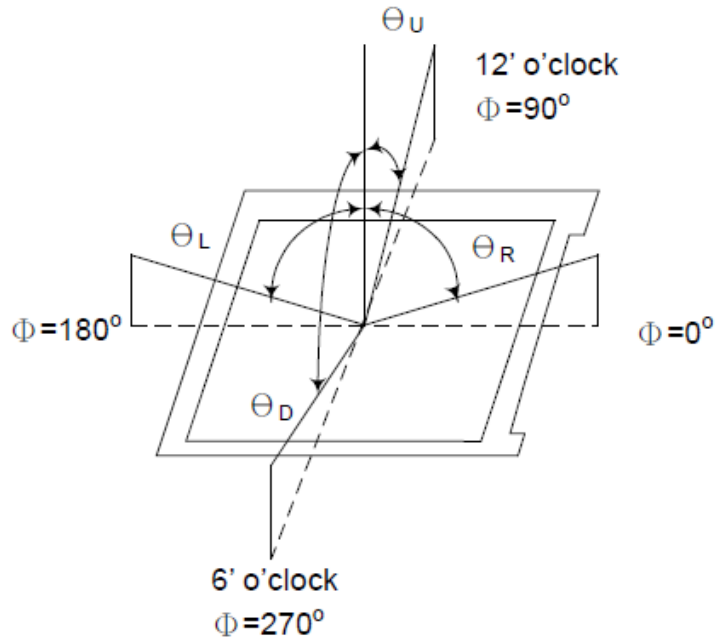

**Note (2):** Definition of Contrast Ratio(CR) :measured at the center point of panel

$$CR = \frac{\text{Luminance with all pixels white}}{\text{Luminance with all pixels black}}$$

**Note (3):** Response Time

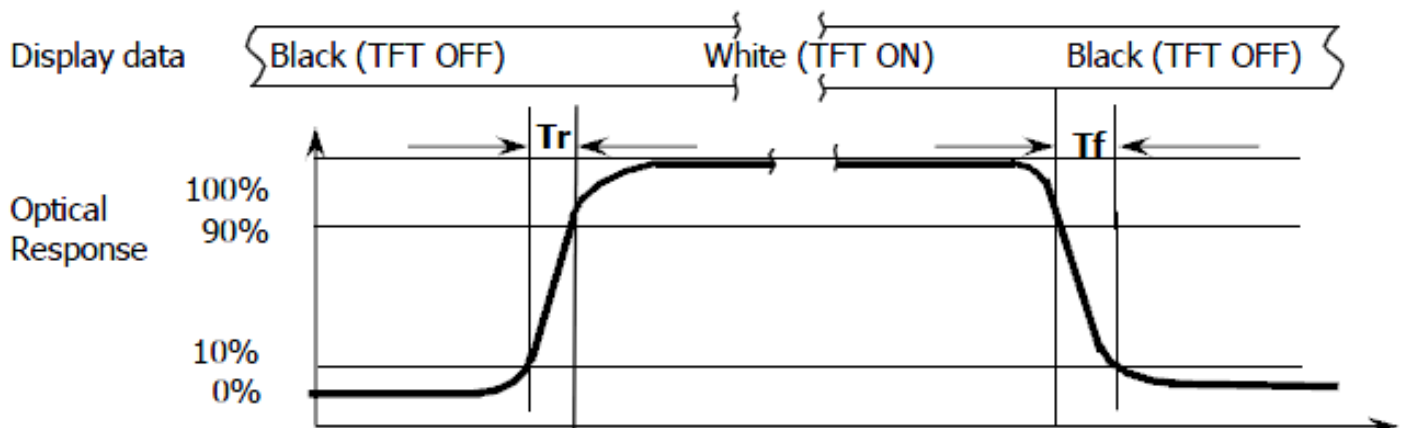

Part. No	KD038HDFPD002-C001A	REV	V1.0	Page 10 of 34
常备库存 Stock For Sale	长期供货 Long Time supply	支持小量 NO MOQ	品种齐全 In Full Range	

**Note (4):** Definition of optical measurement setup

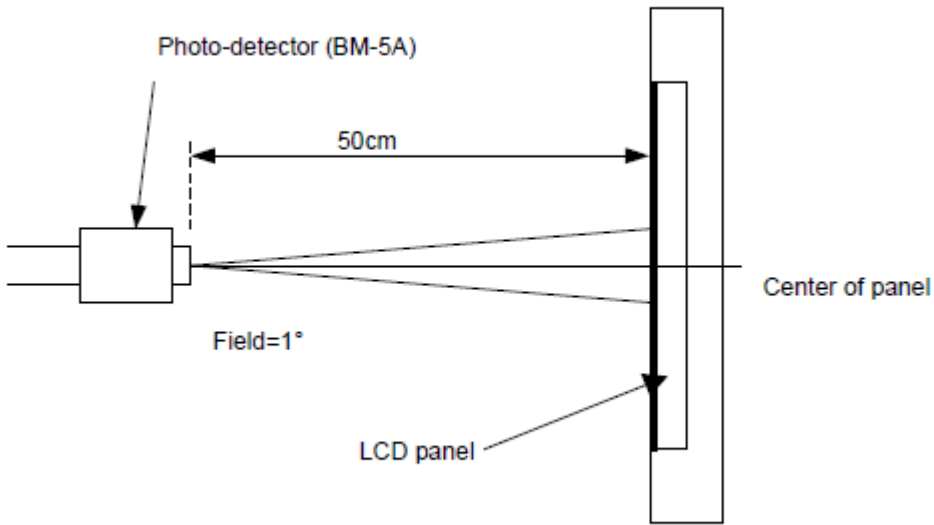

Part. No	KD038HDFPD002-C001A	REV	V1.0	Page 11 of 34
常备库存 Stock For Sale	长期供货 Long Time supply	支持小量 NO MOQ	品种齐全 In Full Range	

## 6. Electrical Characteristics

### 6.1 Absolute Maximum Rating

Characteristics	Symbol	Min.	Max.	Unit	Note
Digital Supply Voltage	VDD	-0.3	3.6	V	Note1
Operating temperature	T <sub>OP</sub>	-20	+70	°C	
Storage temperature	T <sub>ST</sub>	-30	+80	°C	

NOTE1: If the absolute maximum rating of even is one of the above parameters is exceeded even momentarily, the quality of the product may be degraded. Absolute maximum ratings, therefore, specify the values exceeding which the product may be physically damaged. Be sure to use the product within the range of the absolute maximum ratings.

### 6.2 DC Electrical Characteristics

Characteristics	Symbol	Min.	Typ.	Max.	Unit	Note
Digital Supply Voltage	VDD	2.5	3.3	3.6	V	
Normal mode Current	IDD	--	70		mA	
Level input voltage	V <sub>IH</sub>	0.7* VDD	--	VDD	V	
	V <sub>IL</sub>	0	--	0.3* VDD	V	
Level output voltage	V <sub>OH</sub>	0.8 VDD	--	VDD	V	
	V <sub>OL</sub>	0	--	0.2 VDD	V	

Part. No	KD038HDFPD002-C001A	REV	V1.0	Page 12 of 34
常备库存 Stock For Sale	长期供货 Long Time supply	支持小量 NO MOQ	品种齐全 In Full Range	

### 6.3 LED Backlight Characteristics

The back-light system is edge-lighting type with 14 chips LED

Item	Symbol	Min.	Typ.	Max.	Unit	Note
Forward Current	$I_F$	30	40	--	mA	
Forward Voltage	$V_F$	19.6	21.35	23.1	V	
LCM Luminance	LV	710	810		cd/m <sup>2</sup>	Note3
LED life time	Hr	--	50000	--	Hour	Note1,2
Uniformity	Avg	80	--	--	%	Note3

Note1: LED life time (Hr) can be defined as the time in which it continues to operate under the condition:

$T_a=25\pm3\text{ }^\circ\text{C}$ , typical IL value indicated in the above table until the brightness becomes less than 50%.

Note 2: The “LED life time” is defined as the module brightness decrease to 50% original brightness at

$T_a=25\text{ }^\circ\text{C}$  and  $I_L=40\text{ mA}$ . The LED lifetime could be decreased if operating  $I_L$  is larger than 40mA. The constant current driving method is suggested.

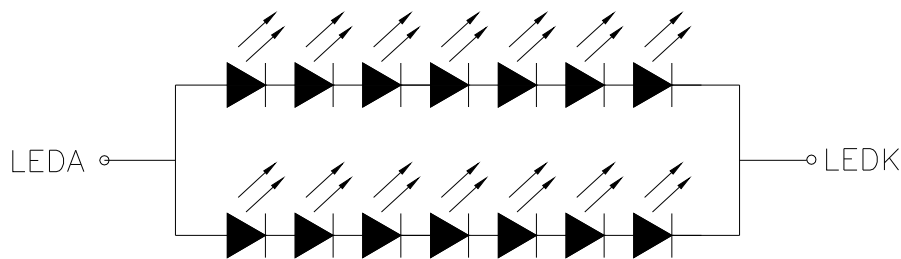

LED (B/L) CIRCUIT

Part. No	KD038HDFPD002-C001A	REV	V1.0	Page 13 of 34
常备库存 Stock For Sale	长期供货 Long Time supply	支持小量 NO MOQ	品种齐全 In Full Range	

Note (3) Luminance Uniformity of these 9 points is defined as below:

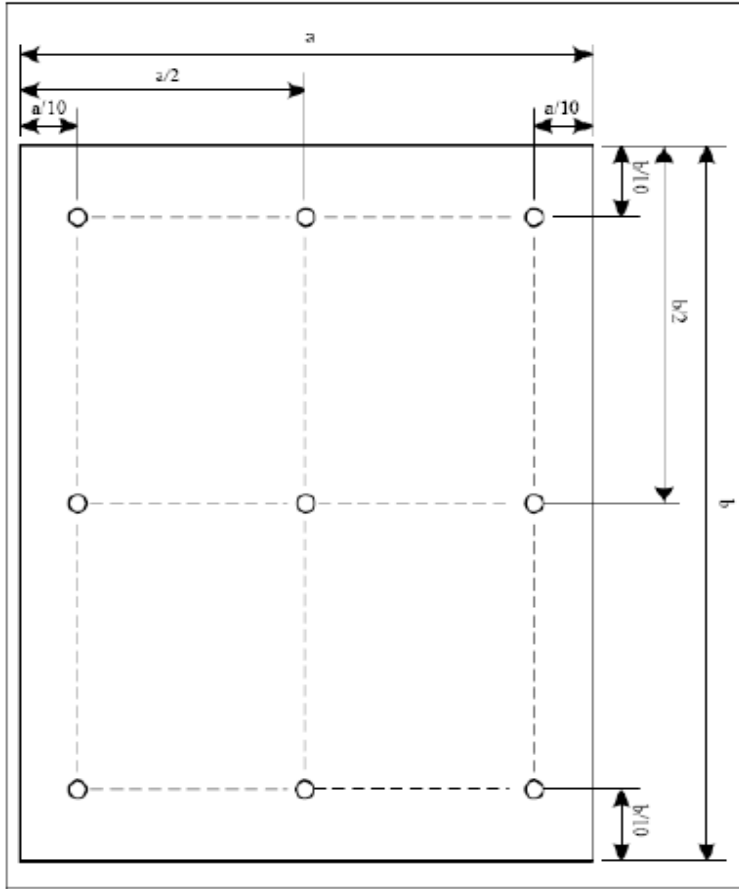

$$\text{Uniformity} = \frac{\text{minimum luminance in 9 points (1-9)}}{\text{maximum luminance in 9 points (1-9)}}$$

$$\text{Luminance} = \frac{\text{Total Luminance of 9 points}}{9}$$

Part. No	KD038HDFPD002-C001A	REV	V1.0	Page 14 of 34
常备库存 Stock For Sale	长期供货 Long Time supply	支持小量 NO MOQ	品种齐全 In Full Range	

## 7. AC Characteristic

### 7.1 RGB Data format

The JD9168 supports 16-bit, 18-bit or 24-bit parallel RGB interface which includes: HSYNC, VSYNC, DE, PCLK, DB[23:0]. The interface is active after Power On sequence. Pixel clock (PCLK) is running all the time without stopping and it is used to entering HS, VS, DE and D[23:0] lines states when there is a rising edge of the PCLK. The PCLK cannot be used as continue internal clock for other functions of the display module e.g. Sleep In-mode etc. Vertical synchronization (VSYNC) is start signal to receive a “new frame” of the display. This is negative (“-“, “0”, low) active by rising edge of the PCLK-line. Horizontal synchronization (HSYNC) is start signal to receive a “new line” of the frame. This is negative (“-“, “0”, low) active by rising edge of the PCLK- line. Data enable (DE) is used to receive RGB information that should be transferred on the display. This is positive (“+“, “1”, high) active by rising edge of the PCLK-line.

The pixel clock cycle is described in the following figure.

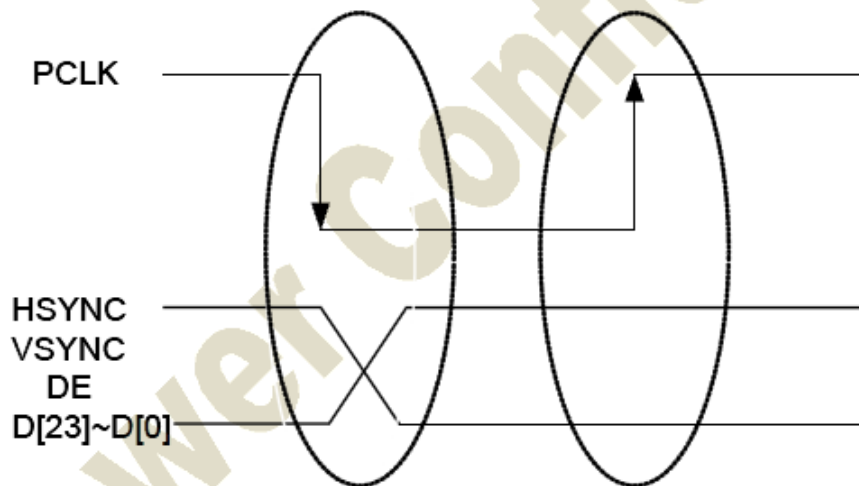

**Note:** PCLK is an unsynchronized signal (It can be stopped).

**Figure 7.9: PCLK cycle**

Data format	D23	D22	D21	D20	D19	D18	D17	D16	D15	D14	D13	D12	D11	D10	D9	D8	D7	D6	D5	D4	D3	D2	D1	D0
16 bit (3Ah=0x50)	R4	R3	R2	R1	R0				G5	G4	G3	G2	G1	G0			B4	B3	B2	B1	B0			
18 bit (3Ah=0x60)	R5	R4	R3	R2	R1	R0			G5	G4	G3	G2	G1	G0			B5	B4	B3	B2	B1	B0		
24 bit (3Ah=0x70)	R7	R6	R5	R4	R3	R2	R1	R0	G7	G6	G5	G4	G3	G2	G1	G0	B7	B6	B5	B4	B3	B2	B1	B0

**Table 7.2: RGB Interface data format**

Part. No	KD038HDFPD002-C001A	REV	V1.0	Page 15 of 34
常备库存 Stock For Sale	长期供货 Long Time supply	支持小量 NO MOQ	品种齐全 In Full Range	

## 7.2 General timing diagram

The image information can be incorrect on the display, when timings are out of the range on the interface (Out of the range timings cannot cause any damage on the display module or it cannot cause any damage on the host side). If it is returned from out of the range to in range timings, then the correct display image must be displayed automatically (by the display module) on the next frame (vertical sync.).

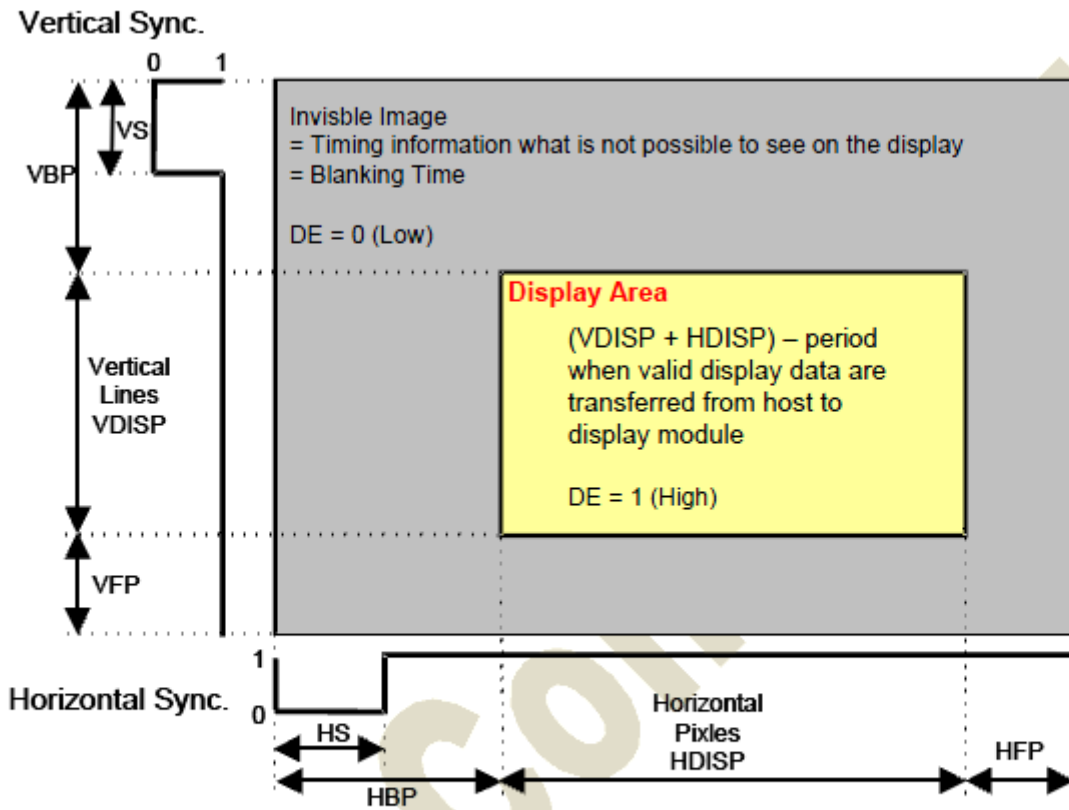

**Figure 7.7: General timing diagram**

Part. No	KD038HDFPD002-C001A	REV	V1.0	Page 16 of 34
常备库存 Stock For Sale	长期供货 Long Time supply	支持小量 NO MOQ	品种齐全 In Full Range	



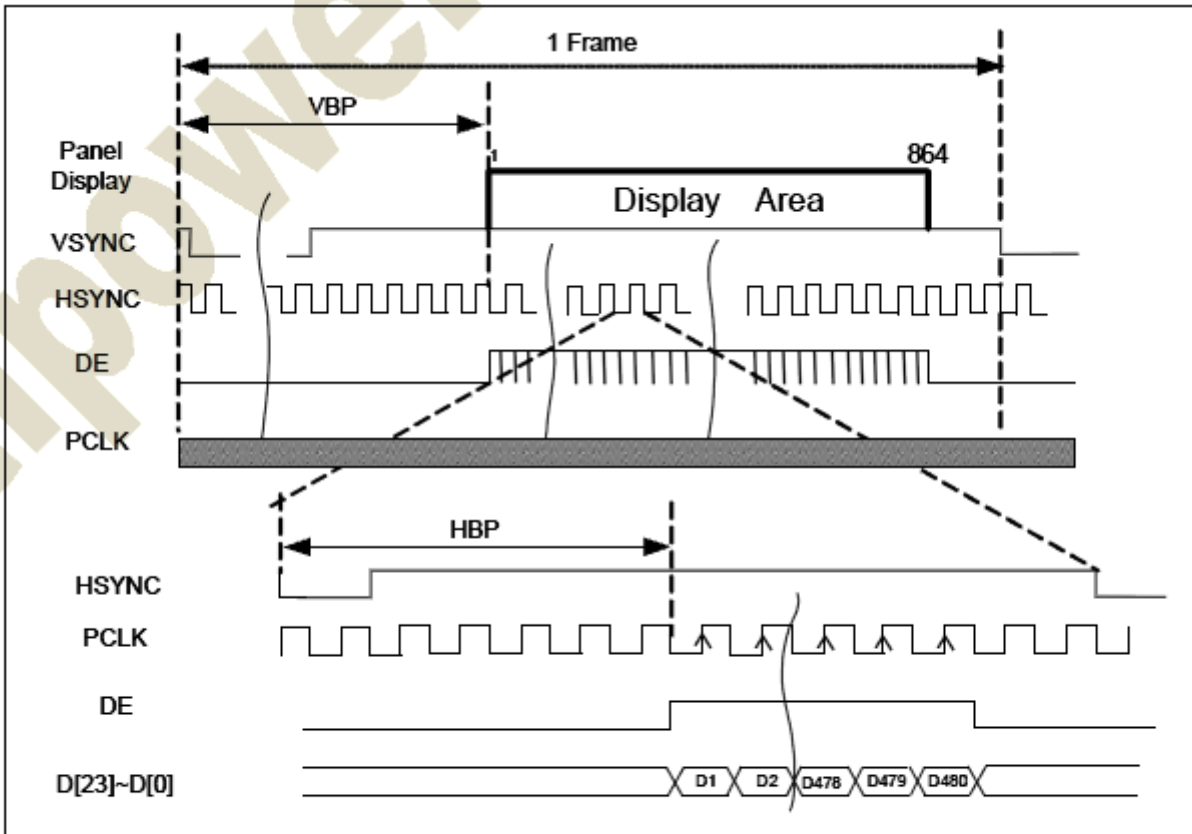

**Figure 7.8: RGB (800RGB x 480) timing diagram**

Part. No	KD038HDFPD002-C001A	REV	V1.0	Page 17 of 34
常备库存 Stock For Sale	长期供货 Long Time supply	支持小量 NO MOQ	品种齐全 In Full Range	

## 8. CTP Specification

### 8.1 Electrical Characteristics

#### 8.1.1 Absolute Maximum Rating

Item	Symbol	Min.	Max.	Unit	Note
Power Supply Voltage	VDD	2.66	3.47	V	
Operating temperature	T <sub>OP</sub>	-30	+85	°C	
Storage temperature	T <sub>ST</sub>	-30	+85	°C	

#### 8.1.2 DC Electrical Characteristics (Ta=25°C)

(Ambient temperature:25°C, VDD=2.8V, VDDIO=1.8V or VDDIO=VDD)

Item	Min.	Typ.	Max.	Unit	Note
Power Supply Voltage/VDD	2.66	3.3	3.47	V	
Normal mode operating current	--	8	14.5	mA	
Green mode operating current	--	3.3	--	mA	
Sleep mode operating current	70	--	120	uA	
Doze mode operating current	--	0.78	--	mA	
Digital Input low voltage/VIL	-0.3	--	0.25*VDD	V	
Digital Input high voltage/VIH	0.75*VDD	--	VDD+0.3	V	
Digital Output low voltage/VOL	--	--	0.15*VDD	V	
Digital Output high voltage/VOH	0.85*VDD	--	--	V	

Part. No	KD038HDFPD002-C001A	REV	V1.0	Page 18 of 34
常备库存 Stock For Sale	长期供货 Long Time supply	支持小量 NO MOQ	品种齐全 In Full Range	

### 8.1.3 AC Characteristics

(Ambient temperature:25℃, VDD=2.8V, VDDIO=1.8V)

Parameter	Min	Typ	Max	Unit	Note
OSC oscillation frequency	59	60	61	MHZ	
I/O output rise time,low to high	-	14	-	ns	
I/O output rfall time,high to low	-	14	-	ns	

### 8.2 I2C Timing

GT911 provides a standard I2C interface for SCL and SDA to communicate with the host. GT911 always serves as slave device in the system with all communication being initialized by the host. It is strongly recommended that transmission rate be kept at or below 400Kbps. The I2C timing is shown below:

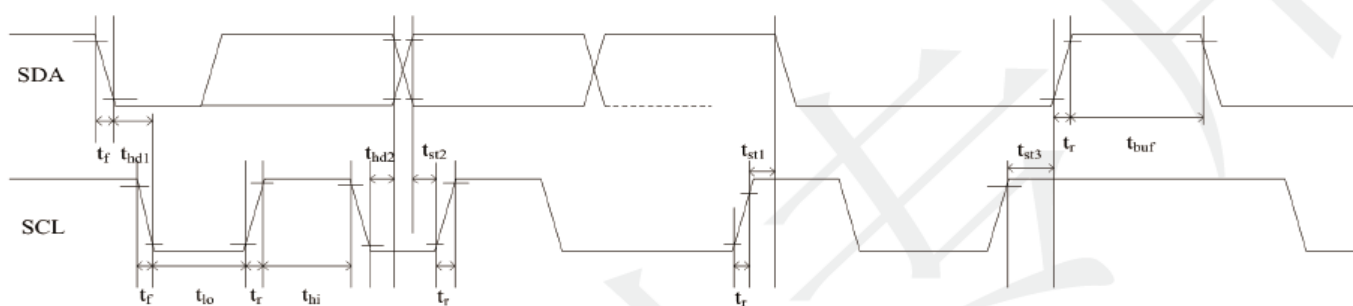

Part. No	KD038HDFPD002-C001A	REV	V1.0	Page 19 of 34
常备库存 Stock For Sale	长期供货 Long Time supply	支持小量 NO MOQ	品种齐全 In Full Range	

**Test condition 1: 1.8V host interface voltage, 400Kbps transmission rate, 2K pull-up resistor**

Parameter	Symbol	Min.	Max.	Unit
SCL low period	$t_{lo}$	1.3	-	us
SCL high period	$t_{hi}$	0.6	-	us
SCL setup time for Start condition	$t_{st1}$	0.6	-	us
SCL setup time for Stop condition	$t_{st3}$	0.6	-	us
SCL hold time for Start condition	$t_{hd1}$	0.6	-	us
SDA setup time	$t_{st2}$	0.1	-	us
SDA hold time	$t_{hd2}$	0	-	us

**Test condition 2: 3.3V host interface voltage, 400Kbps transmission rate, 2K pull-up resistor**

Parameter	Symbol	Min.	Max.	Unit
SCL low period	$t_{lo}$	1.3	-	us
SCL high period	$t_{hi}$	0.6	-	us
SCL setup time for Start condition	$t_{st1}$	0.6	-	us
SCL setup time for Stop condition	$t_{st3}$	0.6	-	us
SCL hold time for Start condition	$t_{hd1}$	0.6	-	us
SDA setup time	$t_{st2}$	0.1	-	us
SDA hold time	$t_{hd2}$	0	-	us

GT911 supports two I2C slave addresses: 0xBA/0xBB and 0x28/0x29. The host can select the address by changing the status of Reset and INT pins during the power-on initialization phase. See the diagram below for configuration methods and timings:

**Power-on Timing:**

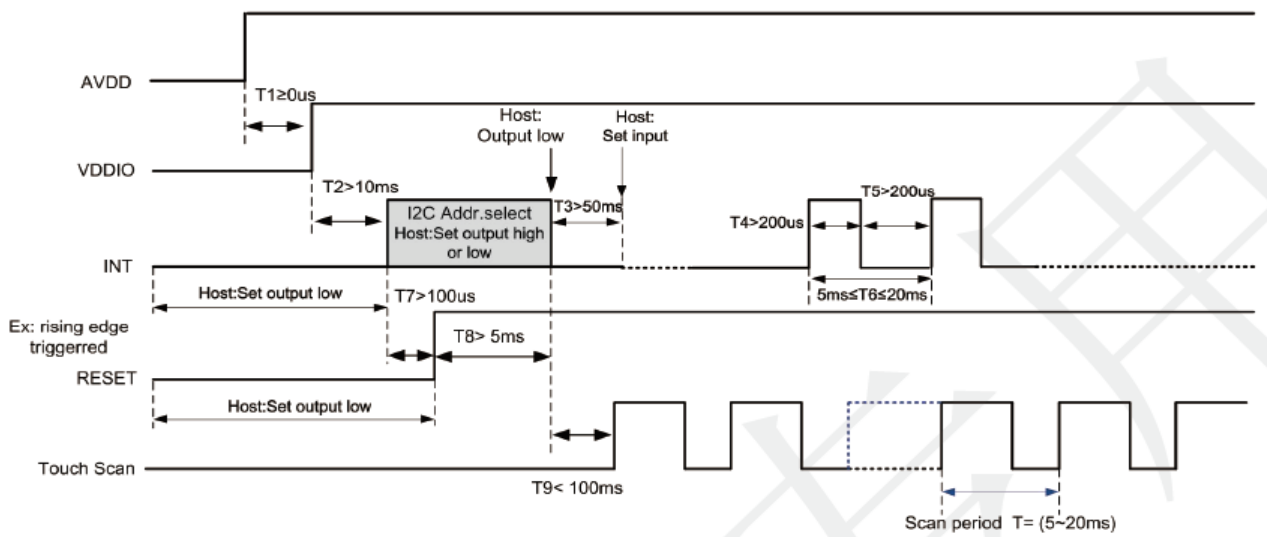

Part. No	KD038HDFPD002-C001A	REV	V1.0	Page 20 of 34
常备库存 Stock For Sale	长期供货 Long Time supply	支持小量 NO MOQ	品种齐全 In Full Range	

**Timing for host resetting GT911:**

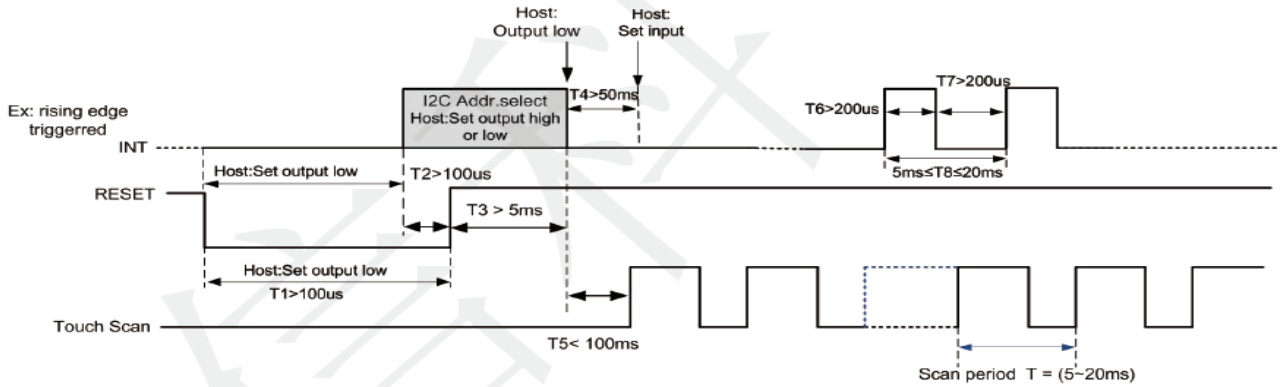

**Timing for setting slave address to 0x28/0x29:**

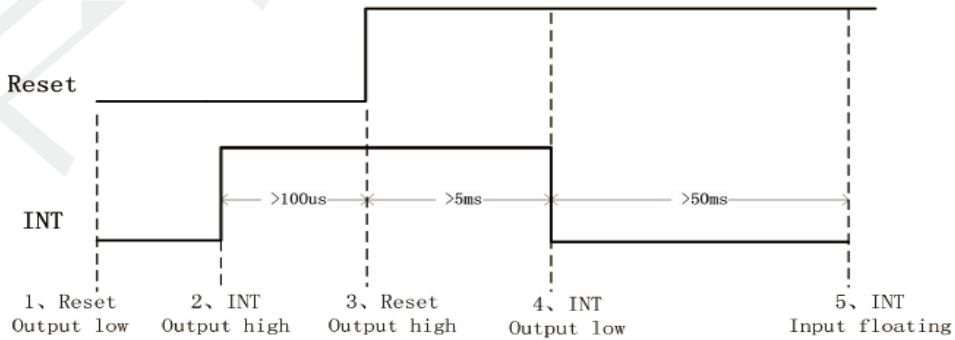

**Timing for setting slave address to 0xBA/0xBB:**

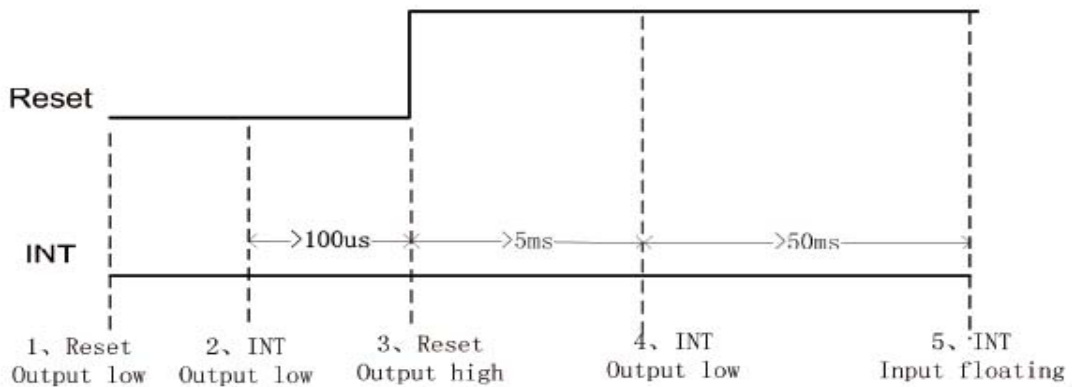

Part. No	KD038HDFPD002-C001A	REV	V1.0	Page 21 of 34
常备库存 Stock For Sale	长期供货 Long Time supply	支持小量 NO MOQ	品种齐全 In Full Range	

**a) Data Transmission**

(For example: device address is 0xBA/0xBB)

Communication is always initiated by the host. Valid Start condition is signaled by pulling SDA line from “high” to “low” when SCL line is “high”. Data flow or address is transmitted after the Start condition.

All slave devices connected to I<sup>2</sup>C bus should detect the 8-bit address issued after Start condition and send the correct ACK. After receiving matching address, GT911 acknowledges by configuring SDA line as output port and pulling SDA line low during the ninth SCL cycle. When receiving unmatched address, namely, not 0xBA or 0xBB, GT911 will stay in an idle state.

For data bytes on SDA, each of 9 serial bits will be sent on nine SCL cycles. Each data byte consists of 8 valid data bits and one ACK or NACK bit sent by the recipient. The data transmission is valid when SCL line is “high”.

When communication is completed, the host will issue the STOP condition. Stop condition implies the transition of SDA line from “low” to “high” when SCL line is “high”.

**b) Writing Data to GT911**

(For example: device address is 0xBA/0xBB)

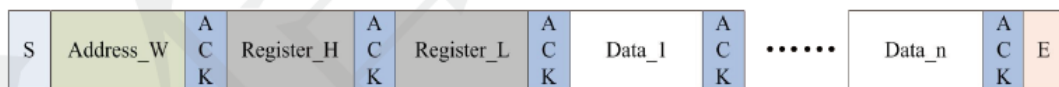

**Timing for Write Operation**

The diagram above displays the timing sequence of the host writing data onto GT911. First, the host issues a Start condition. Then, the host sends 0xBA (address bits and R/W bit; R/W bit as 0 indicates Write operation) to the slave device.

After receiving ACK, the host sends the 16-bit register address (where writing starts) and the 8-bit data bytes (to be written onto the register).

The location of the register address pointer will automatically add 1 after every Write Operation. Therefore, when the host needs to perform Write Operations on a group of registers of continuous addresses, it is able to write continuously. The Write Operation is terminated when the host issues the Stop condition.

Part. No	KD038HDFPD002-C001A	REV	V1.0	Page 22 of 34
常备库存 Stock For Sale	长期供货 Long Time supply	支持小量 NO MOQ	品种齐全 In Full Range	

**c) Reading Data from GT911**

(For example: device address is 0xBA/0xBB)

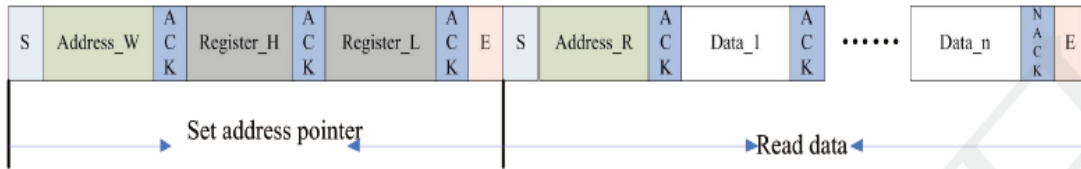

**Timing for Read Operation**

The diagram above is the timing sequence of the host reading data from GT911. First, the host issues a Start condition and sends 0xBA (address bits and R/W bit; R/W bit as 0 indicates Write operation) to the slave device.

After receiving ACK, the host sends the 16-bit register address (where reading starts) to the slave device. Then the host sets register addresses which need to be read.

Also after receiving ACK, the host issues the Start condition once again and sends 0xBB (Read Operation). After receiving ACK, the host starts to read data.

GT911 also supports continuous Read Operation and, by default, reads data continuously. Whenever receiving a byte of data, the host sends an ACK signal indicating successful reception. After receiving the last byte of data, the host sends a NACK signal followed by a STOP condition which terminates communication.

Part. No	KD038HDFPD002-C001A	REV	V1.0	Page 23 of 34
常备库存 Stock For Sale	长期供货 Long Time supply	支持小量 NO MOQ	品种齐全 In Full Range	

## 9. LCD Module Out-Going Quality Level

### 9.1 VISUAL & FUNCTION INSPECTION STANDARD

#### 9.1.1 Inspection conditions

Inspection performed under the following conditions is recommended.

Temperature :  $25 \pm 5^\circ\text{C}$

Humidity :  $65\% \pm 10\% \text{RH}$

Viewing Angle : Normal viewing Angle.

Illumination: Single fluorescent lamp (300 to 700Lux)

Viewing distance:30-50cm

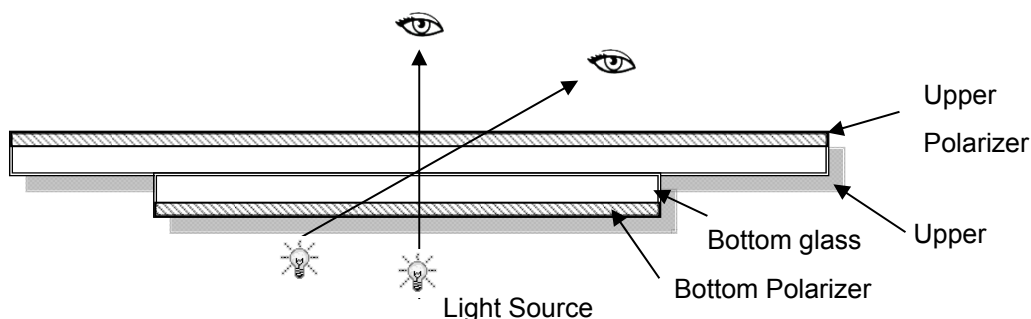

#### 9.1.2 Definition

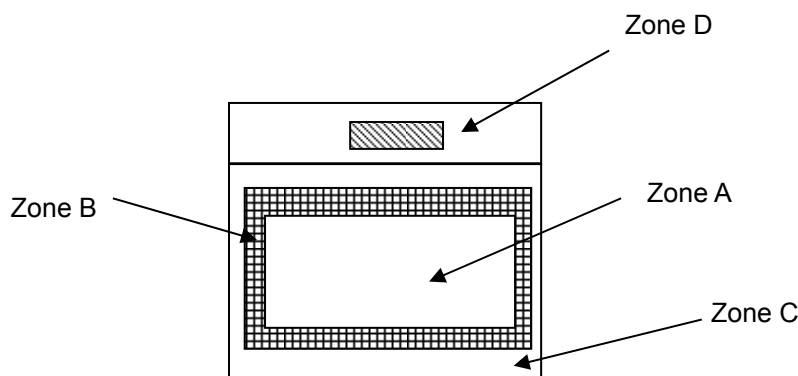

Zone A : Effective Viewing Area(Character or Digit can be seen)

Zone B : Viewing Area except Zone A

Zone C : Outside (Zone A+Zone B) which can not be seen after assembly by customer .)

Zone D : IC Bonding Area

Note:As a general rule ,visual defects in Zone C can be ignored when it doesn't effect product function or appearance after assembly by customer

Part. No	KD038HDFPD002-C001A	REV	V1.0	Page 24 of 34
常备库存 Stock For Sale	长期供货 Long Time supply	支持小量 NO MOQ	品种齐全 In Full Range	



### 9.1.3 Sampling Plan

According to GB/T 2828-2003 ; , normal inspection, Class II

AQL:

Major defect	Minor defect
0.65	1.5

LCD: Liquid Crystal Display , LCM: Liquid Crystal Module, CTP: Capacitive Touch Panel

No	Items to be inspected	Criteria	Classification of defects
1	Functional defects	1) No display, Open or miss line 2) Display abnormally, Short 3) Backlight no lighting, abnormal lighting. etc	Major
2	Missing	Missing components and etc	
3	Outline dimension	Overall outline dimension beyond the drawing is not allowed, deformation and etc	
4	Color tone	Color unevenness, refer to limited sample	Minor
5	Spot/Line defect	Light dot, Dim spot, (Note1) Polarizer Air Bubble, Polarizer accidented spot and etc.	
6	Soldering appearance	Good soldering , Peeling off is not allowed and etc.	
7	LCD/Polarizer/CTP	Black/White spot/line, scratch, crack, etc.	

**Note1:** a) Light dot: Dots appear bright and unchanged in size in which LCD panel is displaying under black pattern.

b) Dim dot: Dots appear dark and unchanged in size in which LCD panel is displaying under pure red, green, blue picture.

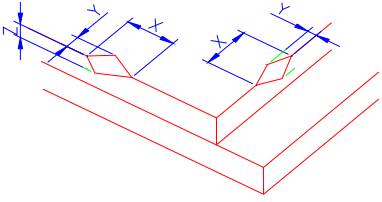
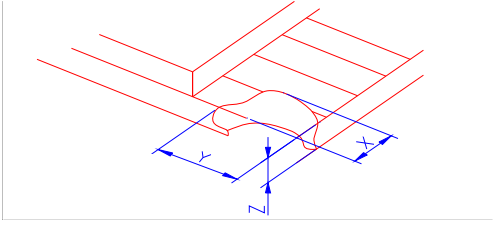
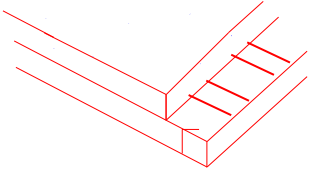

Part. No	KD038HDFPD002-C001A	REV	V1.0	Page 25 of 34
	常备库存 Stock For Sale	长期供货 Long Time supply	支持小量 NO MOQ	品种齐全 In Full Range

### 9.1.4 Criteria (Visual)

Number	Items	Criteria(mm)						
1.0 LCD Crack/Broken NOTE: X: Length Y: Width Z: Height L: Length of ITO, T: Height of LCD	(1) The edge of LCD broken	 <table border="1" data-bbox="756 667 1455 815"> <thead> <tr> <th>X</th> <th>Y</th> <th>Z</th> </tr> </thead> <tbody> <tr> <td>≤3.0mm</td> <td>&lt;Inner border line of the seal</td> <td>≤T</td> </tr> </tbody> </table>	X	Y	Z	≤3.0mm	<Inner border line of the seal	≤T
X	Y	Z						
≤3.0mm	<Inner border line of the seal	≤T						
	(2)LCD corner broken	 <table border="1" data-bbox="836 1124 1375 1223"> <thead> <tr> <th>X</th> <th>Y</th> <th>Z</th> </tr> </thead> <tbody> <tr> <td>≤3.0mm</td> <td>≤L</td> <td>≤T</td> </tr> </tbody> </table>	X	Y	Z	≤3.0mm	≤L	≤T
X	Y	Z						
≤3.0mm	≤L	≤T						
	(3) LCD crack	 <p style="text-align: center;">Crack Not allowed</p>						

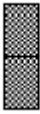
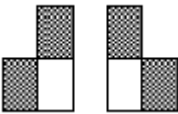

2.0	Spot defect	① light dot ( black/white spot , pinhole, stain, etc.)			
	<p style="text-align: center;"><math>\Phi=(X+Y)/2</math></p>	Zone	Acceptable Qty		
		Size (mm)	A	B	C
		$\Phi \leq 0.15$	Ignore		
		$0.15 < \Phi \leq 0.25$	3(distance $\geq 10$ mm)		
	$0.25 < \Phi \leq 0.4$	2(distance $\geq 10$ mm)			
	$\Phi > 0.4$	0			
		② Dim spot (light leakage、dent、dark spot, etc)			
		Zone	Acceptable Qty		
		Size (mm)	A	B	C
		$\Phi \leq 0.15$	Ignore		
		$0.15 < \Phi \leq 0.25$	3( distance $\geq 10$ mm)		
		$0.25 < \Phi \leq 0.4$	2( distance $\geq 10$ mm)		
		$\Phi > 0.4$	0		
		③ Polarizer accidented spot			
		Zone	Acceptable Qty		
		Size (mm)	A	B	C
		$\Phi \leq 0.2$	Ignore		
		$0.2 < \Phi \leq 0.5$	2( distance $\geq 10$ mm)		
		$\Phi > 0.5$	0		
		④ Polarizer Bubble			
		Zone	Acceptable Qty		
		Size (mm)	A	B	C
		$\Phi \leq 0.2$	Ignore		
		$0.2 < \Phi \leq 0.4$	3(distance $\geq 10$ mm)		
		$\Phi > 0.4$	0		

3.0	LCD Pixel defect	<p>Pixel bad points</p> <table border="1"> <thead> <tr> <th data-bbox="539 309 730 360">Item</th> <th data-bbox="730 309 1241 360">Zone A</th> <th data-bbox="1241 309 1497 360">Acceptable Qty</th> </tr> </thead> <tbody> <tr> <td data-bbox="539 360 730 521" rowspan="3">Bright dot</td> <td data-bbox="730 360 1241 416">Random</td> <td data-bbox="1241 360 1497 416">N≤2</td> </tr> <tr> <td data-bbox="730 416 1241 472">2 dots adjacent</td> <td data-bbox="1241 416 1497 472">N≤0</td> </tr> <tr> <td data-bbox="730 472 1241 521">3 dots adjacent</td> <td data-bbox="1241 472 1497 521">N≤0</td> </tr> <tr> <td data-bbox="539 521 730 689" rowspan="3">Dark dot</td> <td data-bbox="730 521 1241 577">Random</td> <td data-bbox="1241 521 1497 577">N≤2</td> </tr> <tr> <td data-bbox="730 577 1241 633">2 dots adjacent</td> <td data-bbox="1241 577 1497 633">N≤0</td> </tr> <tr> <td data-bbox="730 633 1241 689">3 dots adjacent</td> <td data-bbox="1241 633 1497 689">N≤0</td> </tr> <tr> <td data-bbox="539 689 730 1003">Distance</td> <td data-bbox="730 689 1241 1003">           1. Minimum Distance Between Bright dots.            2. Minimum Distance Between dark dots            3. Minimum Distance Between dark and bright dot.         </td> <td data-bbox="1241 689 1497 1003">5mm</td> </tr> <tr> <td colspan="2" data-bbox="539 1003 1241 1059">Total bright and dark dot</td> <td data-bbox="1241 1003 1497 1059">N≤4</td> </tr> </tbody> </table> <p>Note:</p> <p>A) Bright dot: Dots appear bright and unchanged in size in which LCD panel is displaying under black pattern.</p> <p>B) Dark dot: Dots appear dark and unchanged in size in which LCD panel is displaying under pure red, green, blue picture.</p> <p>C) 2 dot adjacent = 1 pair = 2 dots</p> <p>Picture:</p> <div style="display: flex; justify-content: space-around; align-items: flex-start;"> <div style="text-align: center;">  <p>2 dot adjacent</p> </div> <div style="text-align: center;">  <p>2 dot adjacent</p> </div> </div> <div style="display: flex; justify-content: space-around; align-items: flex-start; margin-top: 20px;"> <div style="text-align: center;">  <p>2 dot adjacent (vertical)</p> </div> <div style="text-align: center;">  <p>2 dot adjacent (slant)</p> </div> </div>	Item	Zone A	Acceptable Qty	Bright dot	Random	N≤2	2 dots adjacent	N≤0	3 dots adjacent	N≤0	Dark dot	Random	N≤2	2 dots adjacent	N≤0	3 dots adjacent	N≤0	Distance	1. Minimum Distance Between Bright dots. 2. Minimum Distance Between dark dots 3. Minimum Distance Between dark and bright dot.	5mm	Total bright and dark dot		N≤4
Item	Zone A	Acceptable Qty																							
Bright dot	Random	N≤2																							
	2 dots adjacent	N≤0																							
	3 dots adjacent	N≤0																							
Dark dot	Random	N≤2																							
	2 dots adjacent	N≤0																							
	3 dots adjacent	N≤0																							
Distance	1. Minimum Distance Between Bright dots. 2. Minimum Distance Between dark dots 3. Minimum Distance Between dark and bright dot.	5mm																							
Total bright and dark dot		N≤4																							

4.0	Line defect (LCD /Polarizer backlight black/white line, scratch, stain)  W: width, L : length N : Count	<table border="1"> <thead> <tr> <th rowspan="2">Width(mm)</th> <th rowspan="2">Length(m)</th> <th colspan="3">Acceptable Qty</th> </tr> <tr> <th>A</th> <th>B</th> <th>C</th> </tr> </thead> <tbody> <tr> <td><math>\Phi \leq 0.05</math></td> <td>Ignore</td> <td colspan="2">Ignore</td> <td rowspan="3">Ignore</td> </tr> <tr> <td><math>0.05 &lt; W \leq 0.06</math></td> <td><math>L \leq 4.0</math></td> <td colspan="2"><math>N \leq 3</math></td> </tr> <tr> <td><math>0.06 &lt; W \leq 0.08</math></td> <td><math>L \leq 3.0</math></td> <td colspan="2"><math>N \leq 2</math></td> </tr> <tr> <td><math>W &gt; 0.08</math></td> <td colspan="4">Define as spot defect</td> </tr> </tbody> </table>	Width(mm)	Length(m)	Acceptable Qty			A	B	C	$\Phi \leq 0.05$	Ignore	Ignore		Ignore	$0.05 < W \leq 0.06$	$L \leq 4.0$	$N \leq 3$		$0.06 < W \leq 0.08$	$L \leq 3.0$	$N \leq 2$		$W > 0.08$	Define as spot defect			
		Width(mm)			Length(m)	Acceptable Qty																						
			A	B		C																						
		$\Phi \leq 0.05$	Ignore	Ignore		Ignore																						
		$0.05 < W \leq 0.06$	$L \leq 4.0$	$N \leq 3$																								
$0.06 < W \leq 0.08$	$L \leq 3.0$	$N \leq 2$																										
$W > 0.08$	Define as spot defect																											
5.0	Electronic Components SMT.	Not allow missing parts, solderless connection, cold solder joint, mismatch. The positive and negative polarity opposite																										
6.0	Display color & Brightness.	1. Color: Measuring the color coordinates, The measurement standard according to the datasheet or samples. 2. Brightness: Measuring the brightness of White screen, The measurement standard according to the datasheet or Samples.																										
7.0	LCD Mura/Waving/ Hot spot	Not visible through 5% ND filter in 50% gray or judge by limit sample if necessary.																										

8.0	CTP Related	CTP Cover sensor accidented black/white spot	<table border="1"> <thead> <tr> <th rowspan="2">Size <math>\Phi</math>(mm)</th> <th colspan="3">Acceptable Qty</th> </tr> <tr> <th>A</th> <th>B</th> <th>C</th> </tr> </thead> <tbody> <tr> <td><math>\Phi \leq 0.1</math></td> <td colspan="2">Ignore</td> <td rowspan="4">Ignore</td> </tr> <tr> <td><math>0.1 &lt; \Phi \leq 0.2</math></td> <td colspan="2">3 (distance <math>\geq 10</math>mm)</td> </tr> <tr> <td><math>0.20 &lt; \Phi \leq 0.25</math></td> <td colspan="2">2 (distance <math>\geq 10</math>mm)</td> </tr> <tr> <td><math>\Phi &gt; 0.25</math></td> <td colspan="2">0</td> </tr> </tbody> </table>	Size $\Phi$ (mm)	Acceptable Qty			A	B	C	$\Phi \leq 0.1$	Ignore		Ignore	$0.1 < \Phi \leq 0.2$	3 (distance $\geq 10$ mm)		$0.20 < \Phi \leq 0.25$	2 (distance $\geq 10$ mm)		$\Phi > 0.25$	0	
			Size $\Phi$ (mm)		Acceptable Qty																		
				A	B	C																	
			$\Phi \leq 0.1$	Ignore		Ignore																	
			$0.1 < \Phi \leq 0.2$	3 (distance $\geq 10$ mm)																			
$0.20 < \Phi \leq 0.25$	2 (distance $\geq 10$ mm)																						
$\Phi > 0.25$	0																						

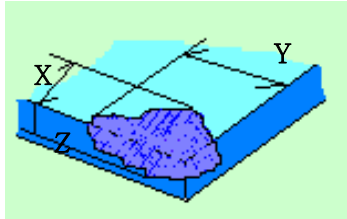

		CTP Cover scratch	<table border="1"> <thead> <tr> <th rowspan="2">Width(mm)</th> <th rowspan="2">Ignore(mm)</th> <th colspan="3">Acceptable Qty</th> </tr> <tr> <th>A</th> <th>B</th> <th>C</th> </tr> </thead> <tbody> <tr> <td><math>\Phi \leq 0.05</math></td> <td>Ignore</td> <td colspan="3">Ignore</td> </tr> <tr> <td><math>0.05 &lt; W \leq 0.06</math></td> <td><math>L \leq 4.0</math></td> <td colspan="3"><math>N \leq 3</math></td> </tr> <tr> <td><math>0.06 &lt; W \leq 0.08</math></td> <td><math>L \leq 3.0</math></td> <td colspan="3"><math>N \leq 2</math></td> </tr> <tr> <td><math>0.08 &lt; W</math></td> <td colspan="4">Define as spot defect</td> </tr> </tbody> </table>	Width(mm)	Ignore(mm)	Acceptable Qty			A	B	C	$\Phi \leq 0.05$	Ignore	Ignore			$0.05 < W \leq 0.06$	$L \leq 4.0$	$N \leq 3$			$0.06 < W \leq 0.08$	$L \leq 3.0$	$N \leq 2$			$0.08 < W$	Define as spot defect			
Width(mm)	Ignore(mm)	Acceptable Qty																													
		A	B	C																											
$\Phi \leq 0.05$	Ignore	Ignore																													
$0.05 < W \leq 0.06$	$L \leq 4.0$	$N \leq 3$																													
$0.06 < W \leq 0.08$	$L \leq 3.0$	$N \leq 2$																													
$0.08 < W$	Define as spot defect																														
		CTP Cover Pinhole/ Lack of ink	<table border="1"> <thead> <tr> <th rowspan="2">Zone Size (mm)</th> <th>Acceptable Qty</th> </tr> <tr> <th>C</th> </tr> </thead> <tbody> <tr> <td><math>\Phi \leq 0.1</math></td> <td>Ignore</td> </tr> <tr> <td><math>0.1 &lt; \Phi \leq 0.25</math></td> <td>3(distance <math>\geq 10</math>mm)</td> </tr> <tr> <td><math>0.25 &lt; \Phi \leq 0.3</math></td> <td>2(distance <math>\geq 10</math>mm)</td> </tr> <tr> <td><math>\Phi &gt; 0.3</math></td> <td>0</td> </tr> </tbody> </table>	Zone Size (mm)	Acceptable Qty	C	$\Phi \leq 0.1$	Ignore	$0.1 < \Phi \leq 0.25$	3(distance $\geq 10$ mm)	$0.25 < \Phi \leq 0.3$	2(distance $\geq 10$ mm)	$\Phi > 0.3$	0																	
Zone Size (mm)	Acceptable Qty																														
	C																														
$\Phi \leq 0.1$	Ignore																														
$0.1 < \Phi \leq 0.25$	3(distance $\geq 10$ mm)																														
$0.25 < \Phi \leq 0.3$	2(distance $\geq 10$ mm)																														
$\Phi > 0.3$	0																														
		CTP Bonding bubble/ accident spot	<table border="1"> <thead> <tr> <th rowspan="2">Size <math>\Phi</math>(mm)</th> <th colspan="2">Acceptable Qty</th> </tr> <tr> <th>A</th> <th>B</th> </tr> </thead> <tbody> <tr> <td><math>\Phi \leq 0.1</math></td> <td colspan="2">Ignore</td> </tr> <tr> <td><math>0.1 &lt; \Phi \leq 0.2</math></td> <td colspan="2">3(distance <math>\geq 10</math>mm)</td> </tr> <tr> <td><math>0.2 &lt; \Phi \leq 0.25</math></td> <td colspan="2">2(distance <math>\geq 10</math>mm)</td> </tr> <tr> <td><math>\Phi &gt; 0.25</math></td> <td colspan="2">0</td> </tr> </tbody> </table>	Size $\Phi$ (mm)	Acceptable Qty		A	B	$\Phi \leq 0.1$	Ignore		$0.1 < \Phi \leq 0.2$	3(distance $\geq 10$ mm)		$0.2 < \Phi \leq 0.25$	2(distance $\geq 10$ mm)		$\Phi > 0.25$	0												
Size $\Phi$ (mm)	Acceptable Qty																														
	A	B																													
$\Phi \leq 0.1$	Ignore																														
$0.1 < \Phi \leq 0.2$	3(distance $\geq 10$ mm)																														
$0.2 < \Phi \leq 0.25$	2(distance $\geq 10$ mm)																														
$\Phi > 0.25$	0																														
		Assembly deflection	beyond the edge of backlight $\leq 0.2$ mm																												
		CTP cover broken X : length Y : width Z : height	<table border="1"> <thead> <tr> <th>X</th> <th>Y</th> <th>Z</th> </tr> </thead> <tbody> <tr> <td><math>X \leq 0.5</math>mm</td> <td><math>Y \leq 0.5</math>mm</td> <td><math>Z &lt; \text{cover thickness}</math> s</td> </tr> </tbody> </table> <p>Circuitry broken is not allowed.</p> 	X	Y	Z	$X \leq 0.5$ mm	$Y \leq 0.5$ mm	$Z < \text{cover thickness}$ s																						
X	Y	Z																													
$X \leq 0.5$ mm	$Y \leq 0.5$ mm	$Z < \text{cover thickness}$ s																													

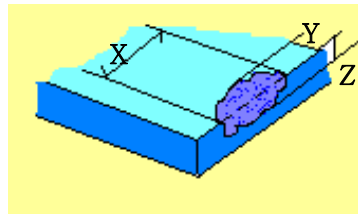
		CTP cover broken X : length Y : width Z : height	X	Y	Z	
			$X \leq 0.3\text{mm}$	$Y \leq 0.3\text{mm}$	$Z < \text{cover thickness}$	
* Circuitry broken is not allowed.						

Criteria ( functional items)

Number	Items	Criteria (mm)
1	No display	Not allowed
2	Missing segment	Not allowed
3	Short	Not allowed
4	Backlight no lighting	Not allowed
5	CTP no function	Not allowed

## 10. Reliability Test Result

Item	Condition	Inspection after test
High Temperature Operating	70°C,96H	Inspection after 2~4hours storage at room temperature, the sample shall be free from defects: 1.Air bubble in the LCD; 2.Non-display; 3.Missing segments/line; 4.Glass crack; 5.Current IDD is twice higher than initial value.
Low Temperature Operating	-20°C, 96HR	
High Temperature Storage	80°C, 96HR	
Low Temperature Storage	-30°C, 96HR	
High Temperature & High	+60°C, 90% RH ,96 hours.	
Thermal Shock (Non-operation)	-30°C,30 min ↔ +80°C,30 min, Change time:5min 20CYC.	
ESD test	C=150pF, R=330,5points/panel Air:±8KV, 5times; Contact:±6KV, 5 times; (Environment: 15°C~35°C, 30%~60%).	
Vibration (Non-operation)	Frequency range:10~55Hz, Stroke:1.5mm Sweep:10Hz~55Hz~10Hz 2 hours for each direction of X.Y.Z. (6 hours for total) (Package condition).	
Box Drop Test	1 Corner 3 Edges 6 faces,80cm(MEDIUM BOX)	

Remark:

- 1.The test samples should be applied to only one test item.
- 2.Sample size for each test item is 5~10pcs.
- 3.For Damp Proof Test, Pure water(Resistance > 10MΩ) should be used.
- 4.In case of malfunction defect caused by ESD damage, if it would be recovered to normal state after resetting, it would be judged as a good part.
- 5.Failure Judgment Criterion: Basic Specification, Electrical Characteristic, Mechanical Characteristic, Optical Characteristic.

Part. No	KD038HDFPD002-C001A	REV	V1.0	Page 32 of 34
常备库存 Stock For Sale	长期供货 Long Time supply	支持小量 NO MOQ	品种齐全 In Full Range	



## 11. Cautions and Handling Precautions

### 11.1 Handling and Operating the Module

(1) When the module is assembled, it should be attached to the system firmly.

Do not warp or twist the module during assembly work.

(2) Protect the module from physical shock or any force. In addition to damage, this may cause improper operation or damage to the module and back-light unit.

(3) Note that polarizer is very fragile and could be easily damaged. Do not press or scratch the surface.

(4) Do not allow drops of water or chemicals to remain on the display surface.

If you have the droplets for a long time, staining and discoloration may occur.

(5) If the surface of the polarizer is dirty, clean it using some absorbent cotton or soft cloth.

(6) The desirable cleaners are water, IPA (Isopropyl Alcohol) or Hexane.

Do not use ketene type materials (ex. Acetone), Ethyl alcohol, Toluene, Ethyl acid or Methyl chloride. It might permanent damage to the polarizer due to chemical reaction.

(7) If the liquid crystal material leaks from the panel, it should be kept away from the eyes or mouth. In case of contact with hands, legs, or clothes, it must be washed away thoroughly with soap.

(8) Protect the module from static; it may cause damage to the CMOS ICs.

(9) Use finger-stalls with soft gloves in order to keep display clean during the incoming inspection and assembly process.

(10) Do not disassemble the module.

(11) Protection film for polarizer on the module shall be slowly peeled off just before use so that the electrostatic charge can be minimized.

(12) Pins of I/F connector shall not be touched directly with bare hands.

(13) Do not connect, disconnect the module in the "Power ON" condition.

### 11.2 Storage and Transportation.

(1) Do not leave the panel in high temperature, and high humidity for a long time.

It is highly recommended to store the module with temperature from 0 to 35 °C and relative humidity of less than 70%

(2) Do not store the TFT-LCD module in direct sunlight.

(3) The module shall be stored in a dark place. When storing the modules for a long time, be sure to adopt effective measures for protecting the modules from strong ultraviolet radiation, sunlight, or fluorescent light.

(4) It is recommended that the modules should be stored under a condition where no condensation is allowed. Formation of dewdrops may cause an abnormal operation or a failure of the module.

In particular, the greatest possible care should be taken to prevent any module from being operated where condensation has occurred inside.

(5) This panel has its circuitry FPC on the bottom side and should be handled carefully in order not to be stressed.

Part. No	KD038HDFPD002-C001A	REV	V1.0	Page 33 of 34
	常备库存 Stock For Sale	长期供货 Long Time supply	支持小量 NO MOQ	品种齐全 In Full Range

## 12. Packing

TBD

Part. No	KD038HDFPD002-C001A	REV	V1.0	Page 34 of 34
	常备库存 Stock For Sale	长期供货 Long Time supply	支持少量 NO MOQ	品种齐全 In Full Range